

EXPERIMENTING WITH MAGNETIC SENSORS

Magnetic fields are all around us. The Earth itself produces a magnetic field, which is why compasses work. Anytime an electrical current flows in a conductor, a magnetic field is generated. That is why transformers, inductors, and radio antennas work.

There are several different devices that could be used to sense a magnetic field. One of the ones most familiar to electronics hobbyists is the Hall-effect device. However, in this article we'll take a look at a magnetic sensor that is as easy to use, but is more sensitive, more linear, and more temperature stable than typical Hall-effect devices. And just like Hall-effect devices, it can be used to make a variety of instruments, including magnetometers and gradiometers.

For those unfamiliar with them, magnetometers are used in a variety of applications in science and engineering. One high-tech magnetometer is used by Navy aircraft to locate submarines. Radio scientists use magnetometers to monitor solar activity. Archeologists use magnetometers to locate buried artifacts, while marine archeologists and treasure hunters use the devices to locate sunken wrecks and sunken treasure.

Anyway, the device we will be exploring is called a "flux-gate magnetic sensor." The device, in essence, is basically an over-driven magnetic-core transformer in which the "transducible" event is the saturation of the magnetic material. These devices can be made very small and compact, yet will still provide reasonable accuracy.

The most simple form of flux-gate magnetic sensor is shown in Fig. 1A. It consists of a nickel-iron rod used as a core, wound with two coils. One coil is used as the excitation coil, while the

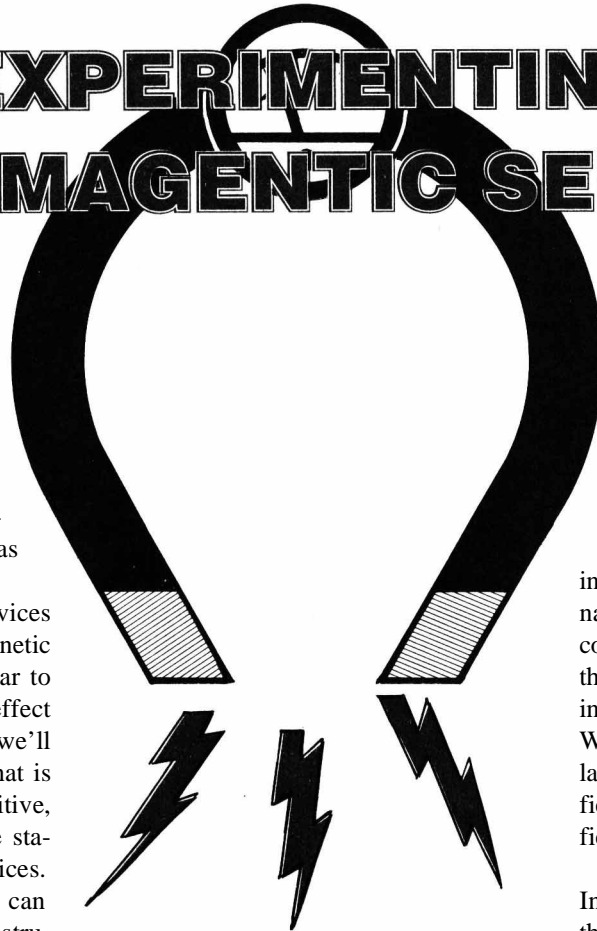

Flux-gate magnetic sensors can provide superior performance to other popular alternatives, and a new device makes them easier than ever to use.

JOSEPH J. CARR

other is used as the output or sensing coil. The excitation coil is driven with a squarewave (see Fig. 1B) with an amplitude high enough to saturate the core. The current in the output coil will increase in a linear manner so long as the core is not saturated. But when the saturation point is reached, the inductance of the coil drops and the current rises to a level limited only by the coil's other circuit resistances.

If the sensor of Fig. 1A were in a magnetically pure environment, then the field produced by the excitation coil

would be the end of the story. But there are magnetic fields all around us, and these either add to or subtract from the magnetic field in the core of the flux-gate sensor. Magnetic field lines along the axis of the core have the most effect on the total magnetic field inside the core. As a result of the external magnetic fields, the saturation condition occurs either earlier or later than would occur if we were only dealing with the magnetic field of interest. Whether the saturation occurs early or later depends on whether the external field opposes or reinforces the intended field.

A better solution is shown in Fig. 2. In this version of the flux-gate sensor, there are two independent cores, each of which has its own excitation winding. A common pick-up winding serves both cores. The excitation coils are wound in a series-opposing manner so that the induction generated in the cores precisely cancels each other if the external field is zero. However, in the presence of an external field, pulses are produced in the pick-up coil that can be integrated in a low-pass filter to produce a slowly varying DC signal that is proportional to the applied external magnetic field.

Toroidal-Core Flux-Gate Sensor.

The flux-gate sensors that use a linear or straight core suffer from two main problems. First, the desired signal is small compared with the signal on which it rides, so is difficult to discriminate properly. Second, there must be a very good match between the cores and the excitation winding segments on each winding. While those problems can be overcome, it becomes expensive, limiting the design's popularity.

A better solution is to use a toroidal or "doughnut"-shaped magnetic core.

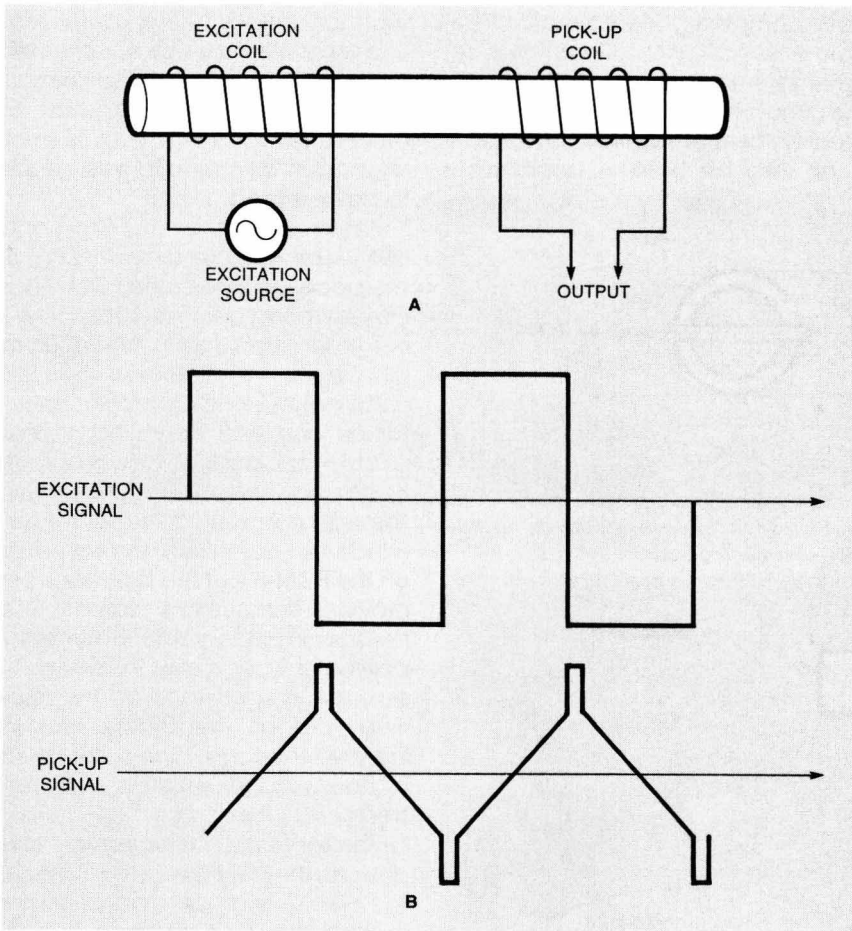

Fig. 1. Here's the flux-gate magnetic sensor in its simplest form (A) and a sample excitation signal and the output that it produces (B).

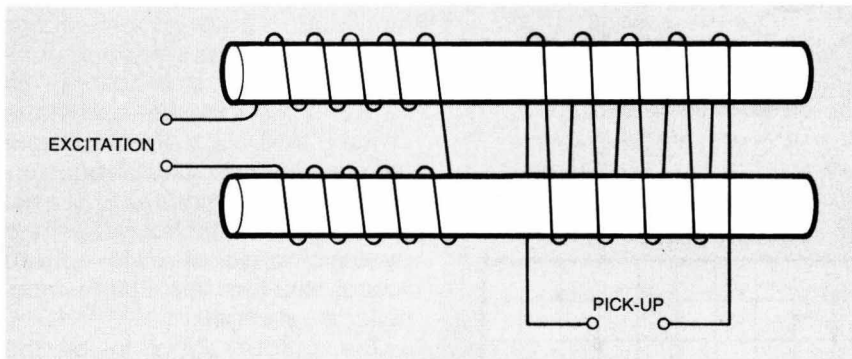

Fig. 2. While the simple circuit of Fig. 1 would work under ideal conditions, because we are constantly surrounded by all kinds of magnetic fields, the dual-core design shows here would produce superior results.

That type of core relieves the problem of picking off small signals in the presence of large offset components. It also reduces the drive levels required from the excitation source.

In the toroidal-core flux-gate sensor, we can get away with using a single excitation coil wound over the entire circumference of the toroidal core (see Fig. 3). The pick-up coil is wound over the outside diameter of the core.

Another advantage of the toroidal-

core version of the flux-gate sensor is that a pair of orthogonal (i.e. right angle) pick-up cores can be installed that will allow null measurements to be made. Figure 4 shows the orientation of the toroid-core flux-gate sensor as a function of sensitivity. The maximum sensitivity occurs when the magnetic H-field is orthogonal to the pick-up coil, while minimum sensitivity occurs when the pick-up coil and H-field are aligned with each other. As you can see, when

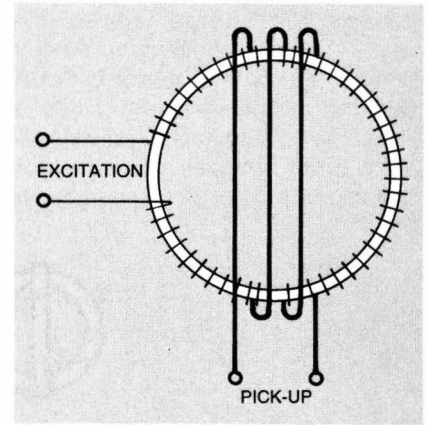

Fig. 3. Using a toroid core overcomes some of the problems and limitations inherent in the straight-core design

there are two pick-up coils at right angles to each other, one will be at maximum sensitivity when the other is at a null (minimum sensitivity).

A Practical Flux-Gate Sensor.

A compact and reasonably low-cost line of flux-gate sensors, designated FGM-x, is made by Speake & Co. Ltd. (Elvicta Estate, Crickhowell, Powys, Wales, UK; Web: <http://www.speake-sensors.com>), and distributed in the United States by Fat Quarters Software (24774 Shoshonee Drive, Murrieta, CA 92562; Tel: 909-698-7950, Fax: 909-698-7913; Web: <http://www.fatquarterssoftware.com>). The FGM-3 device is the one that I experimented with when preparing this article. It is a 62mm-long by 16mm-diameter (2.44 by 0.63 inch) device. Like all the devices in the line, it converts the magnetic field strength to a signal with a proportional frequency. One of the things I found fascinating about the FGM-3 is that a set of only three leads provides operation: Red: +5 VDC (power), Black: 0 Volts (ground), and White: output signal (a squarewave whose frequency varies with the applied field).

The magnetic detection rating of the device is ± 0.5 oersted ($\pm 50 \mu\text{tesla}$). That range covers the earth's magnetic field, making it possible to use the sensor in Earth-field magnetometers. Using two or three sensors in conjunction with each other provides functions such as compass orientation, three-dimensional orientation measurement systems, and three-dimensional gimballed devices such as virtual-reality helmet display devices. It can also be used in applica-

tions such as ferrous metal detectors, underwater shipwreck finders, and in factories as conveyer-belt sensors or counters. There are a host of other applications where a small change in a magnetic field needs to be detected.

The packages for the FGM-1 and FGM-3 sensors are shown in Fig. 5. The package style of the FGM-3 has already been discussed. The FGM-1 is smaller than the FGM-3 (30mm long by 8mm diameter; 1.18 by 0.315 inches). It has a

small connector on one end consisting of four pins: 1) feedback; 2) signal output; 3) ground; and 4) +5 VDC power. The signal, output, and ground terminals are essentially the same as on the FGM-3, but the feedback pin provides some extra flexibility. The feedback pin leads to an internal coil that is wound over the flux-gate sensor. It is used to alter the zero-field output frequency, or to improve linearity of the sensor over its entire range, which is ± 0.7 oersted ($\pm 70 \mu\text{tesla}$).

The series also includes two other devices, the FGM-2 and the FGM-3h. The FGM-2 is an orthogonal sensor that has two FGM-1 devices on a circular platform at right angles to one another. That orthogonal arrangement permits easier implementation of orientation measurement, compass, and other applications. The FGM-3h is the same size and shape as the FGM-3, but is about 2.5 times more sensitive. Its output frequency changes approximately 2 to 3 Hz per gamma of field change, with a dynamic range of ± 0.15 oersted (about one-third the Earth's magnetic field strength).

The output signal in all the devices in the FGM series is +5 volt (TTL-compatible) pulse whose period is directly proportional to the applied magnetic field strength. This relationship makes the frequency of the output signal directly proportional to the magnetic field strength (Fig. 6). The period varies typically from $8.5 \mu\text{s}$ to $25 \mu\text{s}$ or a frequency of about 120 kHz to 50 kHz. For the FGM-3 the linearity is about 5.5 percent over its ± 0.5 oersted range.

The response pattern of the FGM-x series sensors is shown in Fig. 7. It is a "figure-8" pattern that has major lobes (maxima) along the axis of the sensor, and nulls (minima) at right angles to the sensor axis. This pattern suggests that for any given situation there is a preferred direction for sensor alignment. The long axis of the sensor should be pointed towards the target source. When calibrating or aligning sensor circuits, it is common practice to align the sensor along the east-west direction in order to minimize the effects of the Earth's magnetic field.

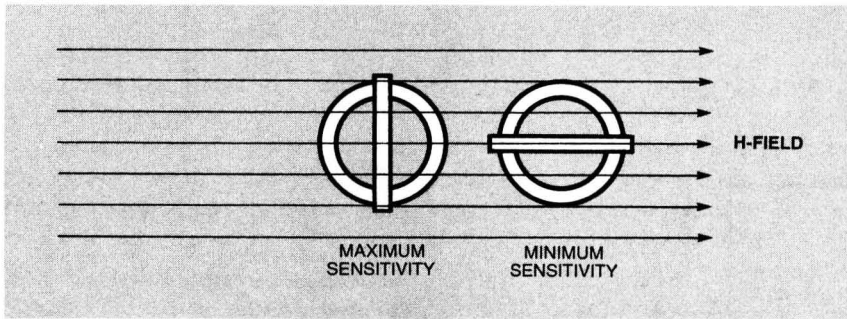

Fig. 4. The sensitivity of the toroid-wound sensor is affected by its orientation within the magnetic field. That property can be put to good use in a variety of sensor applications.

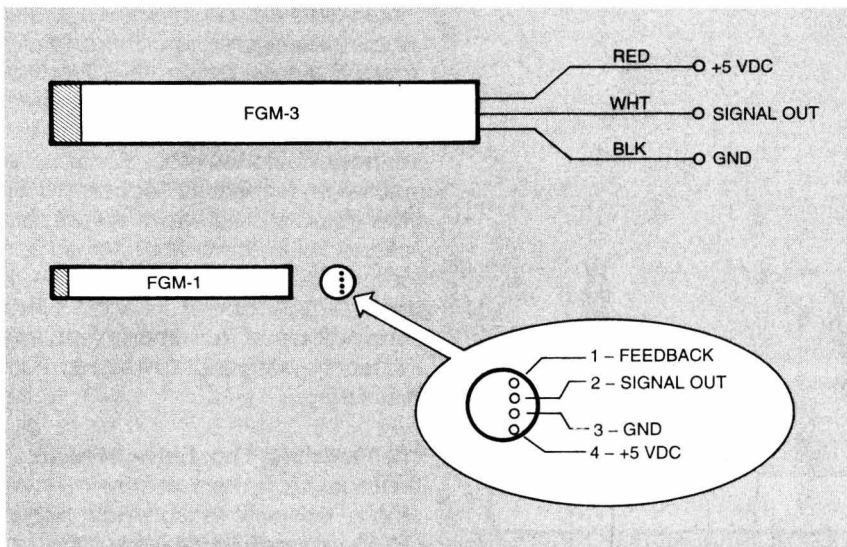

Fig. 5. Here are the pinouts of the FGM-1 and FGM-3, two members of a family of practical flux-gate sensors made in Wales, UK by Speake & Co. Ltd.

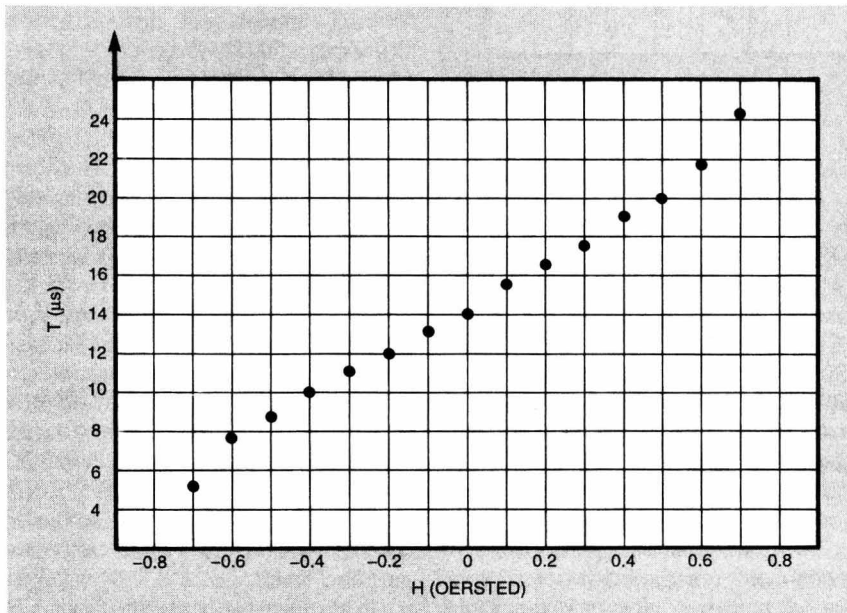

Fig. 6. The output of the FGM devices is directly proportional to the magnetic-field strength.

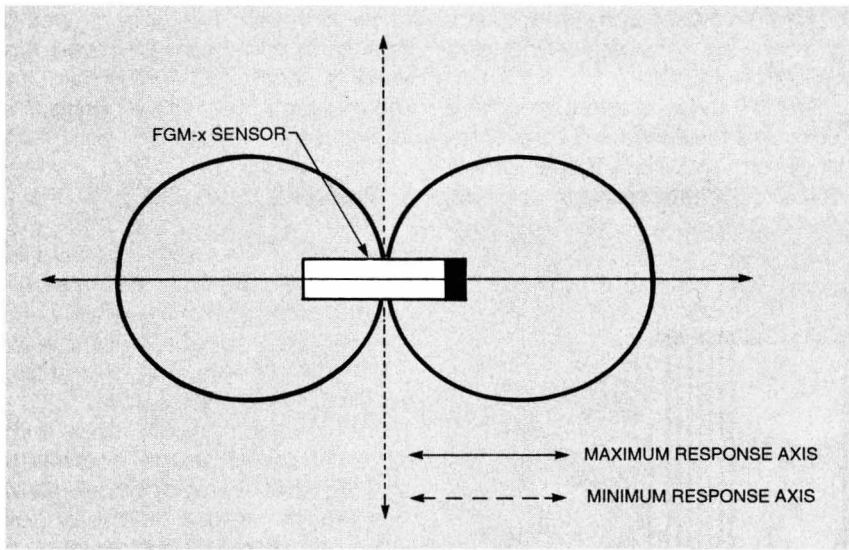

Fig. 7. The figure-eight sensitivity pattern for the FGM-x devices makes them most sensitive along their long axis, and least sensitive at right angles to it.

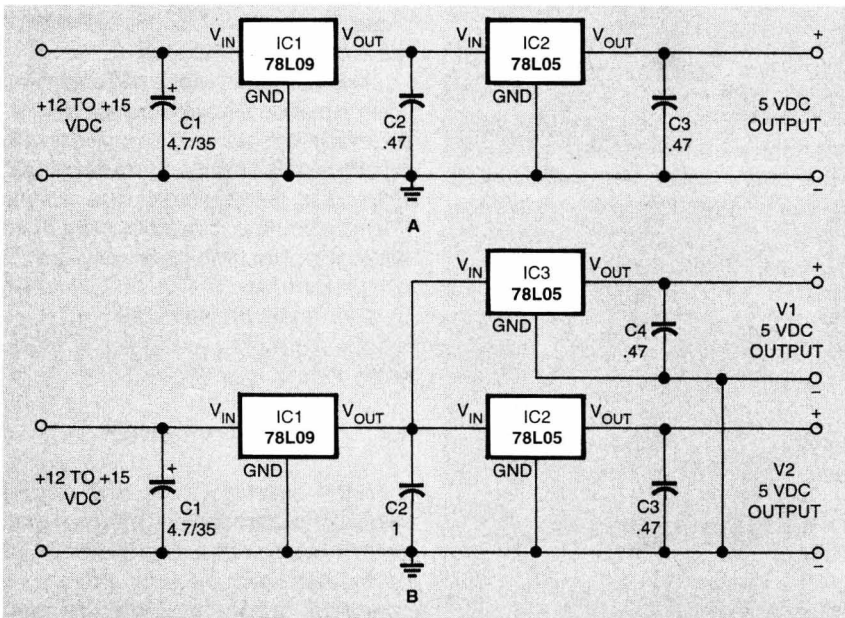

Fig. 8. As ripple will adversely affect the operation of the device, a double-regulated DC power supply (A) should be used to power the device. If other circuits are also to be driven from the supply, use the version shown in B.

Powering the Sensors.

The FGM-x series of flux-gate magnetic sensors operates from +5 volts DC, so it is compatible with a wide variety of analog and digital support circuitry. As is usual for any sensor, you will want to use only a regulated DC power supply for the FGM-x devices. In fact, the manufacturer recommends that double-regulation (Fig. 8A) be used. Ripple in the DC power supply can cause output frequency anomalies, and those should be avoided. In the circuit of Fig. 8A, an unregulated +12 to +15 VDC input potential is applied first to a 9 volt 78L09 or 78M09 three-terminal

IC voltage regulator (IC1). That produces a +9 volt regulated potential that is then applied to the input of a 78L05 or 78M05 device (IC2). The second regulator reduces the +9 volts from IC1 to the +5 volts needed for the FGM-x sensors.

When other digital devices are being powered from the same DC power supply it is prudent to provide a separate DC source for the FMG-x sensors. In Fig. 8B we see a circuit that would accomplish that task. There are two separate +5-volt DC outputs, labeled V1 and V2. Both are derived from 78L05 devices that are powered from a single

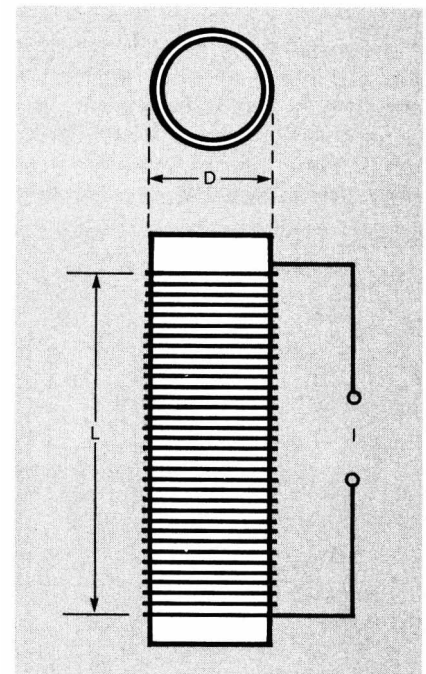

Fig. 9. To calibrate the FGM devices, a solenoid-wound coil like this one could be used.

78L09. Care must be taken to not exceed the maximum current limits of IC1, especially if the same size IC voltage regulators are used for all three (IC1-IC3). One of the +5 VDC sources, either V1 or V2, can be used for powering the FGM-x device, while the other powers the rest of the circuitry.

Calibrating the Sensors.

The FGM-x devices are not precision instruments straight out of the box, but can be calibrated to a very good level of accuracy. The calibration chore requires you to generate a precise magnetic field in which the sensor can be placed. One way to generate well-controlled and easily measured magnetic fields is to build a coil and pass a DC current through it. If the sensor is placed at the center of the coil (inside), then the magnetic field can be determined from the coil geometry, the number or turns of wire, and the current through the coil. There are basically two forms of calibrating coil found in the various magnetic sensor manuals: solenoid-wound and the Helmholtz pair.

Figure 9 shows a solenoid-wound coil, a cell that is wound on a cylindrical form in which the length of the coil (L) is greater than or equal to its diameter. This type of coil is familiar to radio fans because it is used in many L-C tuning circuits. The magnetic field (H) in

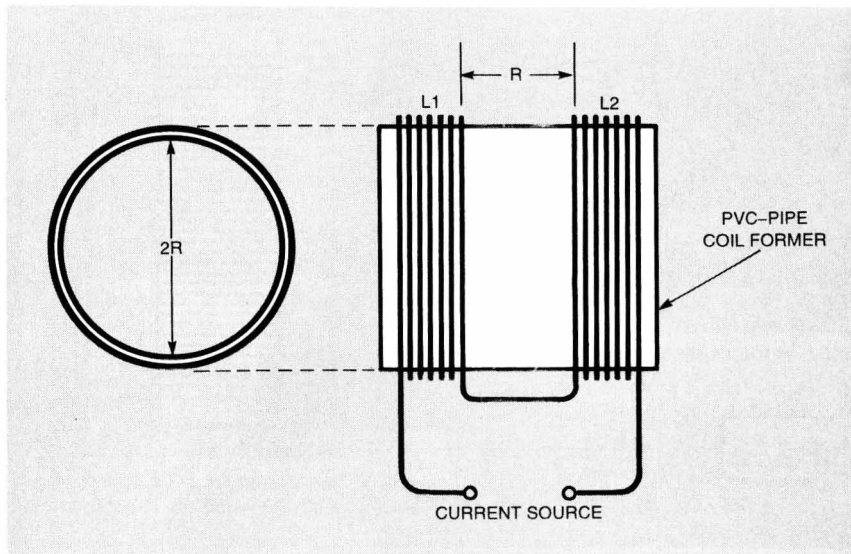

Fig. 10. A Helmholtz-pair calibration coil could also be used, though these can be difficult to wind.

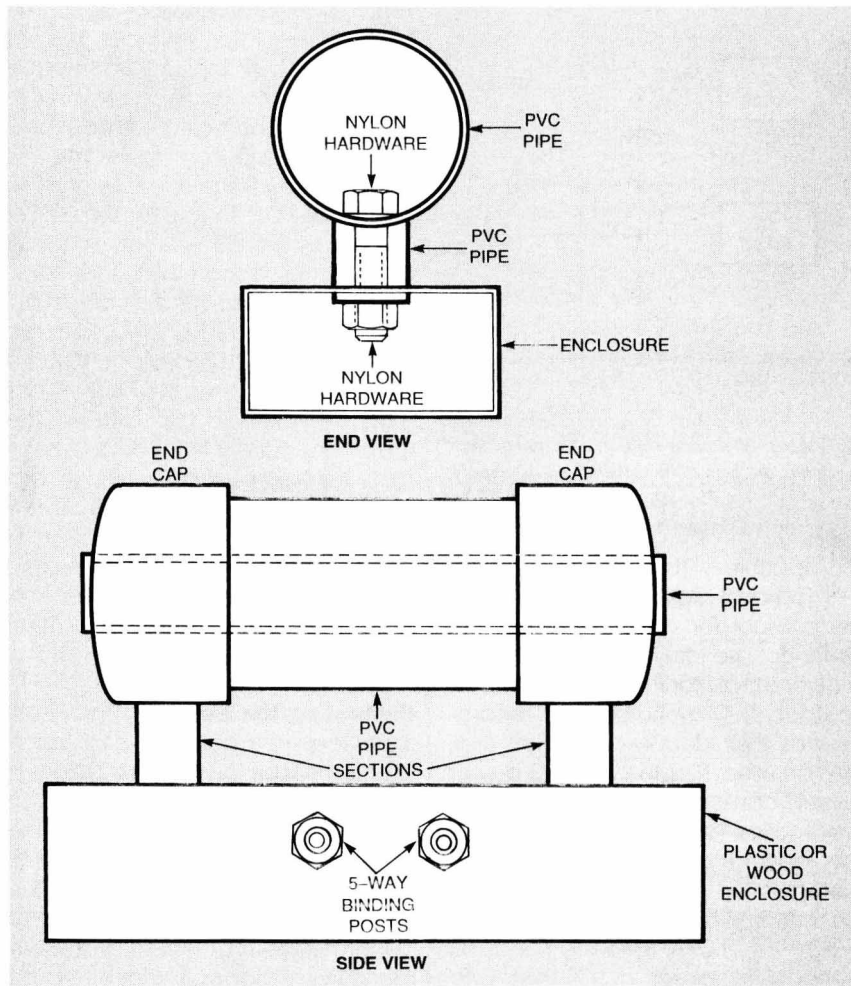

Fig. 11. Here's a simple coil-mounting assembly that can be used in your calibration setup.

oersteds is found from:

$$H = \frac{4\pi NIL}{10\sqrt{L^2 + D^2}}$$

Where: H is the magnetic field in oersteds, N is the number turns-per-centimeter (t/cm) in the winding, I is the

winding current in amperes, and P is the mean diameter of the winding in centimeters (cm).

The winding is usually made with either 24- or 26-gauge enameled or Formvar-covered copper wire. The length of the solenoid coil should be at

least twice as long as the sensor being calibrated, and the sensor should be placed as close as possible to the center of the long axis of the coil. The Helmholtz coil is shown in Fig. 10. It consists of two identical coils (L1 and L2) mounted on a form with a radius of R, and a diameter of 2R. The coils are spaced one radius (1R) apart. The equations for that type of calibration assembly are:

$$H = \frac{0.8991 \cdot NI}{R}$$

and,

$$B = \frac{9.1 \times 10^3 \cdot NI}{R}$$

In the practical case, one usually knows the dimensions of the coil, and needs to calculate the amount of current required to create a specified magnetic field. We can get that for the Helmholtz pair by rearranging the first equation of the pair to:

$$I = \frac{RH}{0.8991 \cdot N}$$

The coils are a little difficult to wind, especially those of large diameter (e.g. 4 inches). One source recommends using double-sided tape (the double-sticky stuff) wrapped around the form where the coils are to be located. As the wires are laid down on the form they will stick to the tape, and not dither around. The above equations, plus a lot of magnetic theory and calibration suggestions are found in *The Magnetic Measurements Handbook* by J.M. Janicke (\$20, Magnetic Research Press, 122 Bellevue Avenue, Butler, NJ, 07405).

Figure 11 shows a type of assembly that can be used for either the solenoid or Helmholtz coil. I first saw this type of assembly in a college freshman physics laboratory about 25 years ago. It consists of a PVC pipe section used as the coil former. End caps on the coil former also serve as mountings. The mounts at either end consist of smaller segments of PVC pipe and nylon (non-magnetic) hardware fasteners. Another segment of PVC pipe, of much smaller diameter than the coil former, is passed through the former from one end-cap to the other, such that its ends protrude to the outside. This pipe forms a channel into which the sensor can be placed. The base is a plastic or wooden box

(again, non-magnetic materials). One thing nice about that type of assembly is that the sensor is always in approximately the same position in the coil, and close to the center of the field.

Conclusion.

Now that we've established a base of understanding of flux-gate sensors, it is

a simple matter to put that knowledge to use to build some practical magnetometer and gradiometer projects. That will be the focus of another article, which will appear shortly. In the meantime, if you have any question or comments on what we've discussed here, you can contact me directly at P0 Box 1099, Falls Church, VA 22041, or via Inter-

net E-mail at carjj@aol.com. Also, before we wrap up, I'd like to acknowledge the assistance of Richard Noble of Speake & Co. Ltd., and Erich Kern of Fat Quarters Software, the USA distributor of Speake sensors.