

# TWIN LOOP TREASURE SEEKER

Robert and David Crone

Pulse metal detectors are powerful and versatile machines but in their basic form they suffer from ground effect and radio interference. However a very simple modification can almost entirely eliminate these two problems.

The principle of the pulse metal detector is very easy to understand. A large pulse of current is transmitted through a coil of wire and the resulting magnetic field induces eddy currents in nearby coins or metal objects. The eddy currents continue to flow after the transmitted pulse has ended and they in turn induce small voltages back into the coil. These voltages are amplified and detected in a receiver which operates an audio indication, usually a click generator.

A problem with this is that the transmitted pulse induces eddy currents in mineralised ground causing a ground effect signal. Secondly the coil acts as a good aerial for long and medium wave radio broadcasts, producing interference. So what can be done about these problems?

The ground effect comes from a large area and is almost constant over a flat surface like a wet sandy beach after the tide has gone out. If we were to position a second search coil about 100mm from the original then it would pick up the same amount of ground effect. Now if we were to subtract the outputs of the two coils the ground effect from each would cancel out. However the system would still pick up coins because the distance between the coils is large compared with a coin. By similar reasoning, medium and long wave radio broadcasts will cancel out as the field strength of these signals does not change significantly in 100mm and each coil will receive the same amount of interference.

So the second coil is a modification to the pulse detection system. Figure 1 shows a block diagram of the unit. The central feature is the search coil assembly which in practice consists of two coils each of 200mm diameter and overlapping by 100mm.

ETI Sept. 1989 Copyright © Wimbourne Publishing

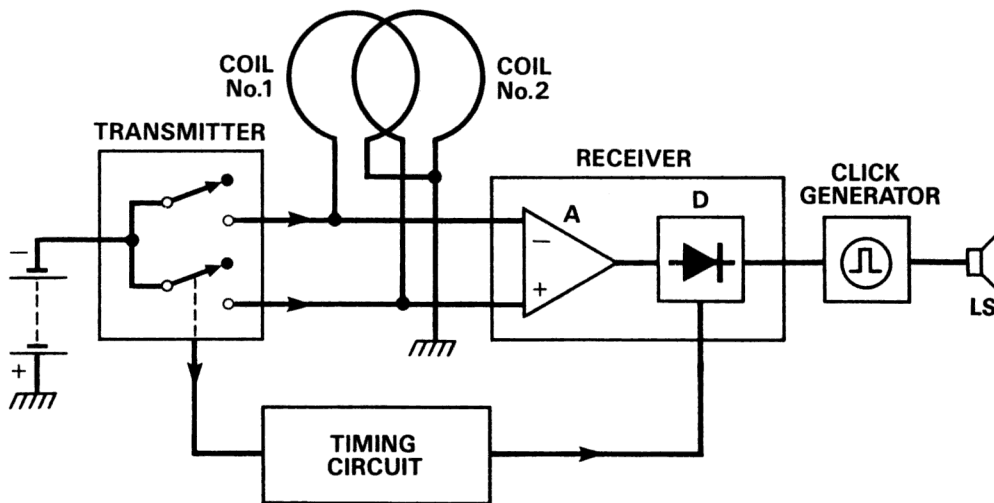

Fig. 1 Block diagram of detector

## The Transmitter

Figure 2 shows the circuit diagram of the transmitter. IC1 is wired as an oscillator running at 100Hz. IC2 is triggered 100 times per second from IC1 via the differentiating network of R3 and C3. Each time IC2 is triggered its output goes high for 165μs and drives the two power transistors hard on into saturation. The full battery voltage is now applied across the coils and the current in each one builds up to about one amp.

## The Timing Circuit

Fig. 3 shows the circuit diagram of the timing circuit. IC3 is triggered from the transmitter at the end of the 165μs current pulse. Its output goes high for 36μs and then IC4 is triggered via C8 and R11. IC4 runs for 50μs and its output goes to the receiver where it switches on the detector for 50μs.

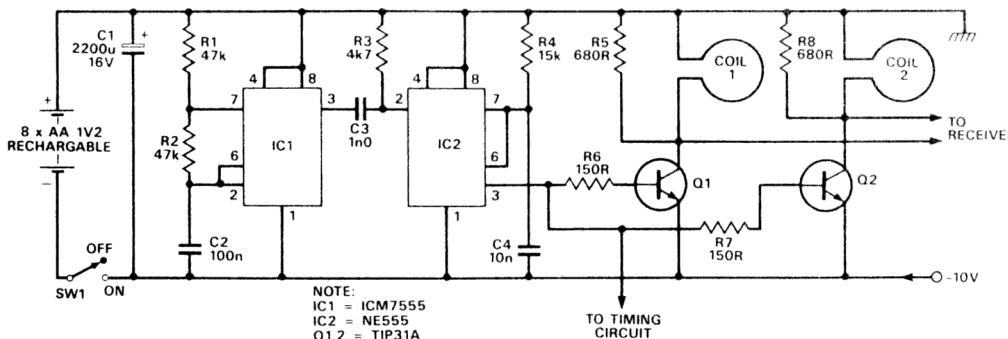

Fig. 2 Circuit diagram of transmitter

## The Receiver

Fig. 4 shows the circuit diagram of the receiver. The outputs from the coils are fed to the inputs of the difference amplifier IC5. Here the ground effect and interference cancel out but the coin signals are amplified and passed on to the next stage. The 709 is used in the IC5 position because its noise figure is good enough for the job. Diodes D1 to D6 protect the op-amp inputs and are configured so that IC5 does not go into an indeterminate state when the diodes are on. Q3 is switched on for 50µs by the timing circuit and allows the coin signals to pass on to the detector and amplifier IC6. When constructed, set pin 6 of IC5 to -1V by adjusting RV1 and set the

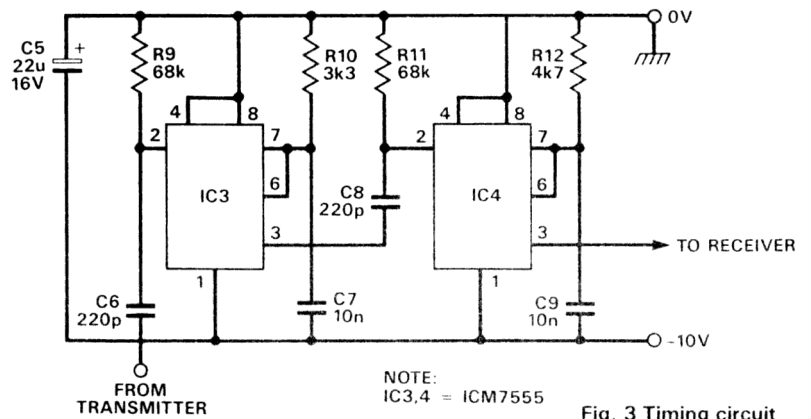

Fig. 3 Timing circuit

ETI Sept. 1989 Copyright © Wimbourne Publishing

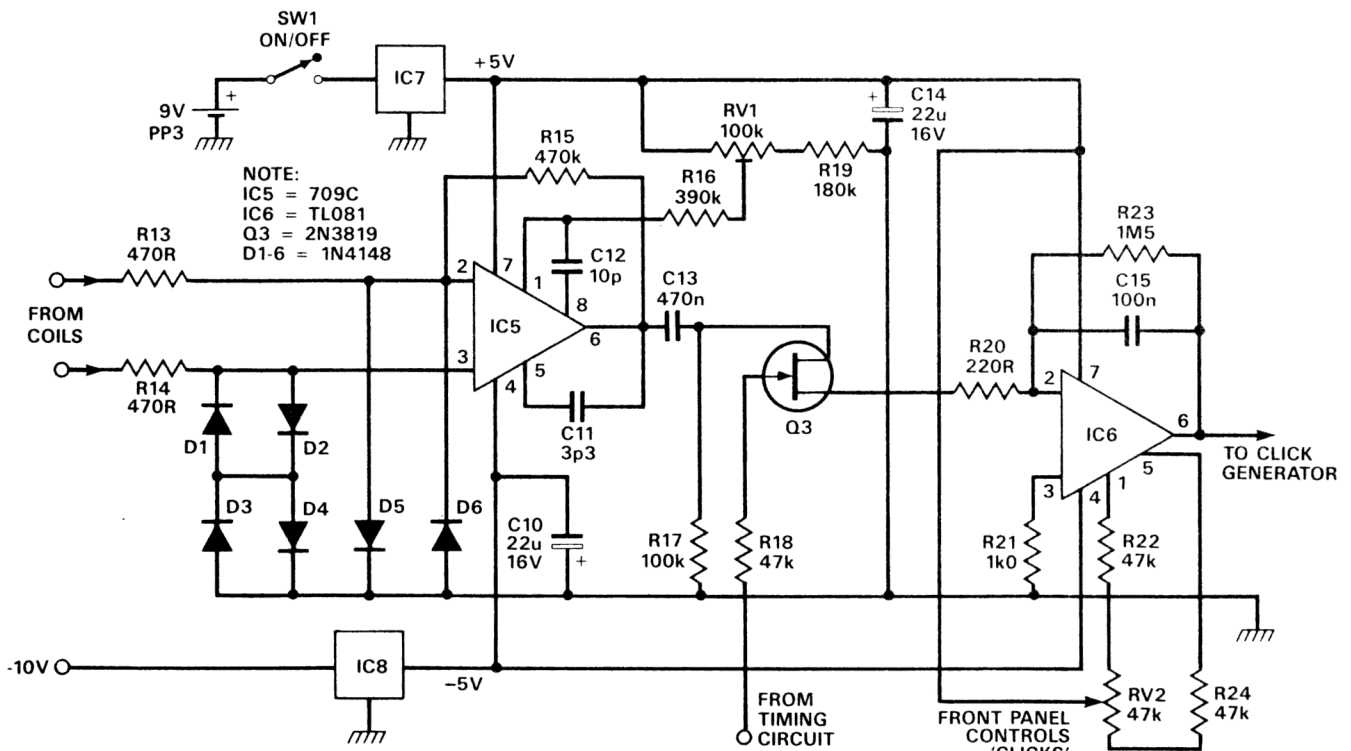

Fig. 4 Circuit diagram of receiver

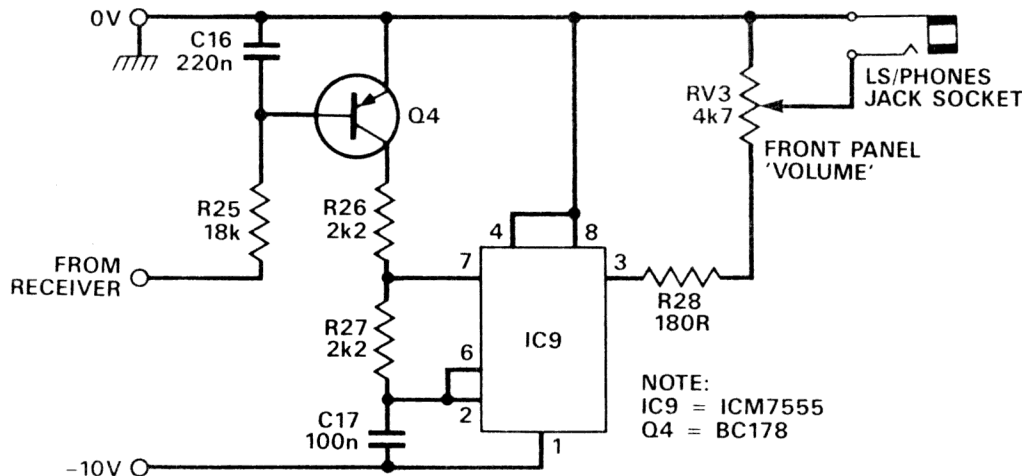

Fig. 5 Diagram of click generator

receiver output to -0.3V by the front panel control RV2.

## The Click Generator

Fig. 5 shows the circuit of the click generator. With no input at all, Q4 is off and the circuit is inoperative. However with -0.3V coming in from the receiver, Q4 starts to conduct very slightly and the circuit starts to click slowly. The clicks rapidly turn into a high pitched whistle as the search coil approaches a coin.

## Construction

The circuit is built on a single PCB and the components should be mounted according to the component overlay in Fig. 6. The usual precautions should be taken with the ICM7555s as these are CMOS devices. You need to keep yourself earthed when handling these chips. Once all the components have been mounted on the PCB, the board can be drilled in the four corners. The board is held firm in a plastic control box by four nylon cuts and bolts. Terminal pins were used on the PCB for external connections to the switches, potentiometers, sockets and battery connections.

Drill the required holes in the plastic control box. You will probably have to do a little additional filing for the volume, click control pots and the audio socket.

To make the search coils first obtain a piece of scrap 25mm chipboard and hammer into it a 200mm diameter circle of nails, wind 30 turns of no 26swg enamelled copper wire around the nails and secure the windings with string or cotton ties. Pull out a few nails, remove the coil and then wind a second coil. Then

mount the coils, overlapping by 100mm as in Fig. 7 on a suitable piece of 6mm plywood and fasten them down with plastic cable clips and plastic screws. Connect the coils up to a few feet of 3-core cable terminated at the other end in 4mm plugs. Alternatively you could use 2-core screened audio cable and use the screen for the common connection.

At this stage you would be advised to bench test the machine to check that you have wound the coils correctly so that the

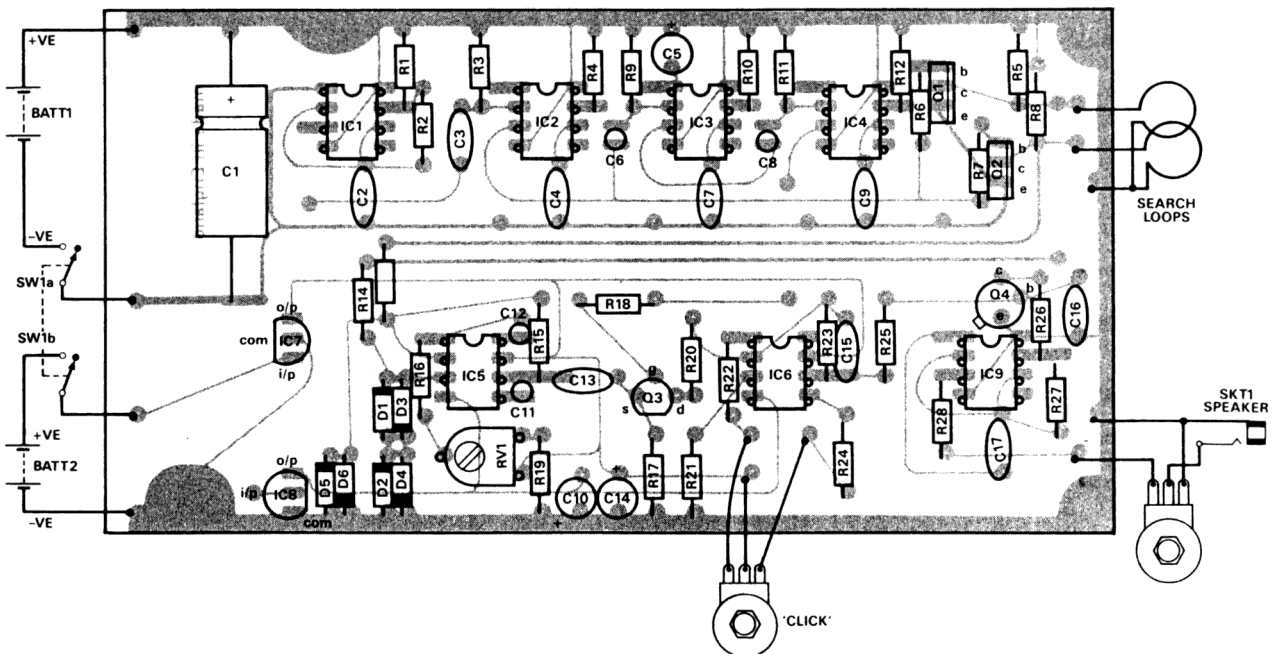
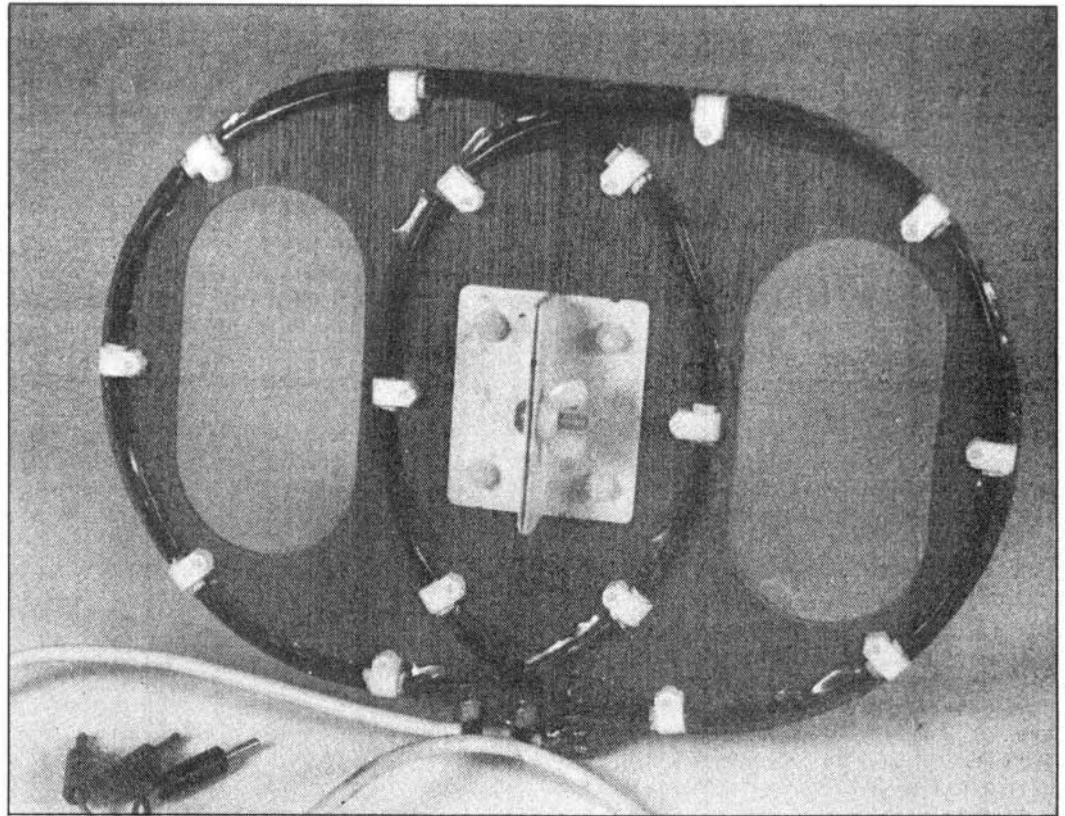

Fig. 6 Component overlay for the detector and off-board wiring

current in each coil flows in the same circular direction. A method of testing the phasing or current direction in each coil, apart from inspection, would be to pass a small direct current through each coil and then detect the magnetic field produced with a small compass. The coils would need to be placed in the vertical plane with the compass positioned at the centre of each ring. If the currents are in the same direction, the compass will indicate that this is so.

### The Printed Circuit Board

Fig. 6 shows the component overlay. Make sure the components are placed in the correct positions. Once the 165µs pulse has finished, the reservoir capacitor C1 starts to charge up with a large current. This causes a voltage drop in the wiring. If any voltage drop gets on to the earth rail, it will be amplified and interfere with the system operation. For this reason separate wiring for the two battery supplies must be used and nothing but the battery may be connected to the left of C1.

### The Coils

Fig. 7 gives the details of the coil assembly. Mount the coils on a plywood frame and cut away as much wood as possible to reduce the weight. A few feet of 3-core mains cable is suitable for connecting the coil assembly to the 4mm sockets on the plastic control box. Everything must be plastic or wood. Finally keep in mind that the current in each coil is flowing in the same direction ie they are driven in phase.

### Batteries

Eight 1.2V AA size rechargeable cells provide the -10V supply. The machine consumes around 80mA of current so the batteries will give about five hours of continuous running. When the batteries are discharged, the click generator will go out of control. A 9V PP3 or MN1604 battery provides the positive supply for the op-amps. A voltage converter is not used to obtain

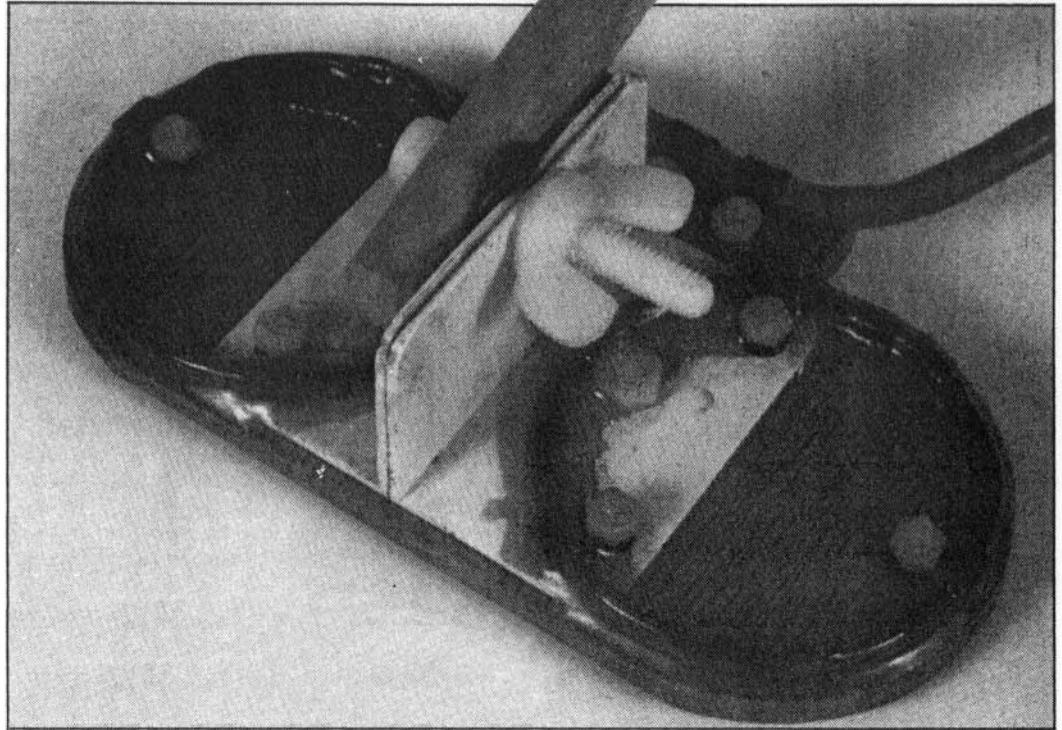

this supply as these devices require an oscillator, the output of which might get into the receiver and cause interference. All the batteries are mounted inside the lid of the plastic control box and secured with strong rubber bands.

Then encapsulate the coils with Araldite and put the assembly into a warming compartment so that the Araldite melts and permeates into the windings before setting. Use plastic angle material to attach the assembly to a plastic or wooden stem. No metal should be used in the construction of the coil assembly. Any metal nuts, screws, washers or solder tags will upset the system.

An 80cm length of 20mm plastic tubing may be used to make the handle for the control box and can be bent into the traditional 'shepherd's crook' shape by means of a bending spring and hot water. A bicycle handlebar grip slipped on to the top end makes an ideal handle hold.

A 50cm straight length of 16mm plastic tubing can be used for the stem. One end was dipped in hot water and flattened with pliers and then attached to the coil assembly by means of a plastic nut and bolt. The stem is then slid up into the handle until the total length suits the operator and then bolted into position. Alternatively one could use a wooden walking stick or adapt whatever non metallic material one has

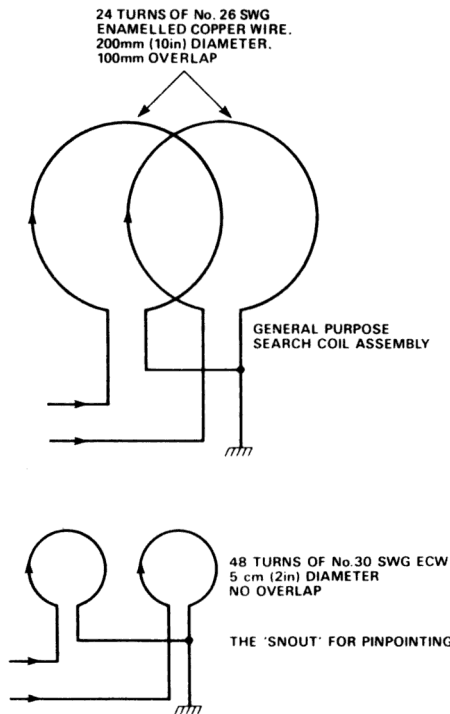

Fig. 7 (a) General purpose search coil assembly  
(b) The snout for pinpointing

to hand. The only metal materials permitted are a few screws in the control box and the two screws securing the control box to the handle. Finally, insert a rubber washer between stem and coil assembly. This gives a non slip attachment to stop the search head angle being moved by rough grass.

### Testing

The initial testing should be done in a metal free environment. Most work benches and tables contain large numbers of nails, screws and brackets so the reader is advised to suspend the coil assembly from the ceiling on a length of string to ensure that it is well clear of metal. With the click generator set to one click per second the operator will notice a significant increase in the click rate if a two pence coin is taken to a distance of 180mm from the search coil.

Once small pieces of metal have been located with the general purpose search coil, the final pinpointing can be carried out with a snout probe shown in Fig. 7b and in the above photograph. This probe was constructed in a similar manner to the general purpose coil except that the coils do not overlap. Each coil is made from 48 turns of 30 swg enamelled copper wire making the loops 50mm in diameter and 70mm between centres.

### How It Works

The operation is as follows. The two switches in the transmitter close simultaneously for 165µs and allow a current of one amp to flow through each coil. This operation is repeated every 10ms (a frequency of 100Hz). The coin signals picked up by the coils along with the interference and ground effect are then routed to the op-amp A in the receiver (Fig. 1). Here the interference and ground effect cancel out and the amplified coin signals are passed on to the detector D. Detector D is switched on by the timing circuit 36µs after the end of the current pulse and for a duration of 50µs. The µs delay is to allow the coils to settle down because the sudden loss of the current causes a very large voltage spike to appear across each coil. The DC output of the detector now goes to the click generator which starts to click rapidly as the search coil approaches a coin.

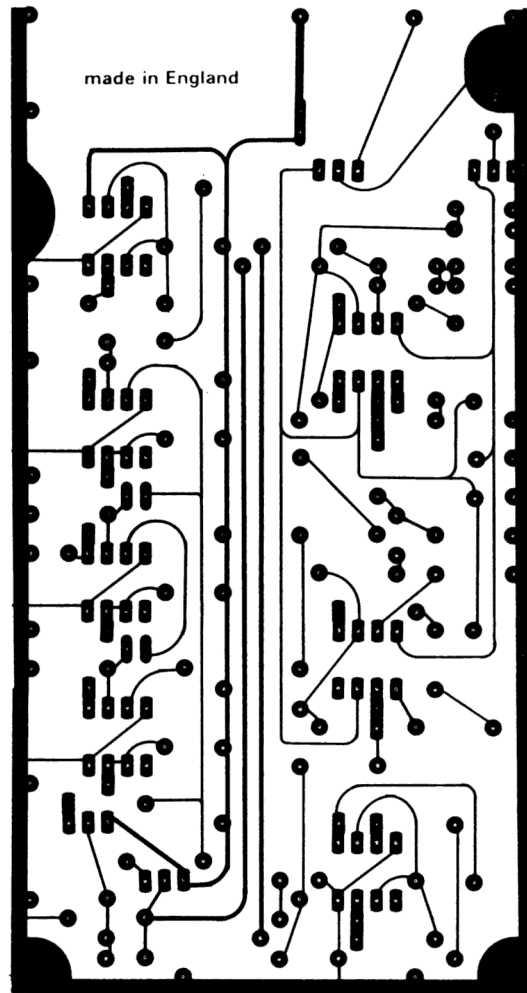

Metal locator foil pattern

## Parts List

### Resistors (all 1/4W 5%)

R1,2,18,22,24	47k
R3,12	4k7
R4	15k
R5,8	680R
R6,7	150R
R9,11	68k
R10	3k3
R13,14	470R
R15	470k
R16	390k
R17	100k
R19	180k
R20	220R
R21	1k0
R23	1M5
R25	18k
R26,27	2k2
R28	180R
RV1	100k horiz preset
RV2	47k lin
RV3	4k7 lin

### Capacitors

C1	2200µ axial electrolytic
C2,15,17	100n polyester 7mm
C3	1n0 polyester 7mm
C4,7,9	10n polyester 7mm
C5,10,14	22µ 16v tant bead
C6,8	220p 63v ceramic
C11	3p3 63v ceramic
C12	10p 63v ceramic
C13	470n polyester 7mm
C16	220n polyester 7mm

### Semiconductors

IC1,3,4,9	ICM7555IPA
IC2	NE555
IC5	µA709CP
IC6	TL081
IC7	78L05
IC8	79L05
Q1,2	TIP31A
Q3	2N3819
Q4	BC178
D1-5	1N4148

### Miscellaneous

BATT1	8x1.2V AA batteries
BATT2	1x9V PP3 battery
PL1-3	4mm plugs: 2 red 1 black
PL4	2.5mm mono jack plug
SK1-3	4mm sockets: 2 red 1 black
SK4	mono 2.5mm chassis jack socket
SW1	DPDT switch

Case. Enamelled copper wire, 28swg and 30swg. Plastic tubing, 16mm and 20mm. 6mm plywood. Plastic angle. Cable grips. Glue (Araldite).